



D40 SPITFIRE LED LIGHT-SURFACE MOUNT



Product Line	24M
Product Group	LED Emergency Luminaires
Product Code	FBESPITD40SMS

Compliance: AS/NZS 60598.2.22 & AS/NZS 60598.1



Features:

- ⚡ Low power consumption
- ⚡ 50,000 hr LED - Energy efficient, Long life
- ⚡ Long life Lithium-Ion battery
- ⚡ Quick-fit bracket ease of installation
- ⚡ Large terminal block
- ⚡ Superior light output achieves higher level of compliance
- ⚡ Supply with flex and plug

Installation Drawing

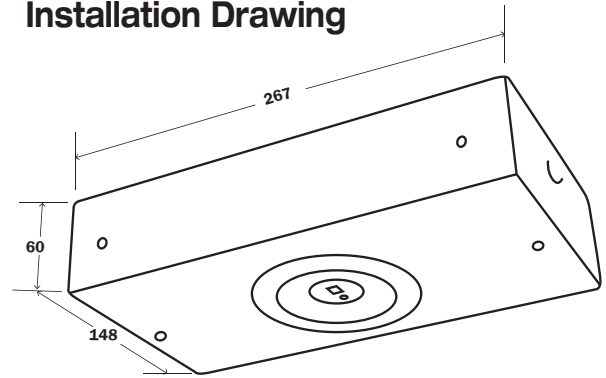

Dimensions (mm)

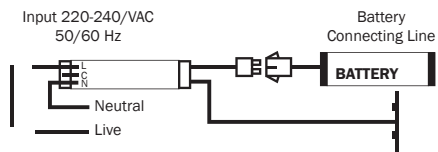

Dimension:

Dimension	Control Gear	Battery
267mm x 148mm x 60mm	150mm x 30mm	65.6mm x 26.2mm

Specifications:

Voltage (V)	Battery Capacity	Frequency (Hz)	Charging Time	Duration	Max. Ambient Temp.	Power Consumption
220 - 240	3200mAh	50/60	16 Hours	2 Hours	50°C	3 Watts
Battery Type	Battery Voltage (V)	Viewing Distance	Mode	Mounting Type	IP Rating	Classification
Li-Ion	3.2	N/A	Non-Maintained	Recessed Mounting	IP20	C0: D40 C90: D40

Spacing Table & Mounting Height:

(m)	2.1	2.4	2.7	3.0	3.3	3.6	4.0	4.5	5.0	6.0	7.0	8.0	9.0	10.0
D40	16.7	17.4	18.0	18.6	19.1	19.6	20.1	20.8	21.3	22.1	22.7	23.0	23.1	23.1

Based on minimum light level of level of 0.2 lux